

General System Layout Sketch

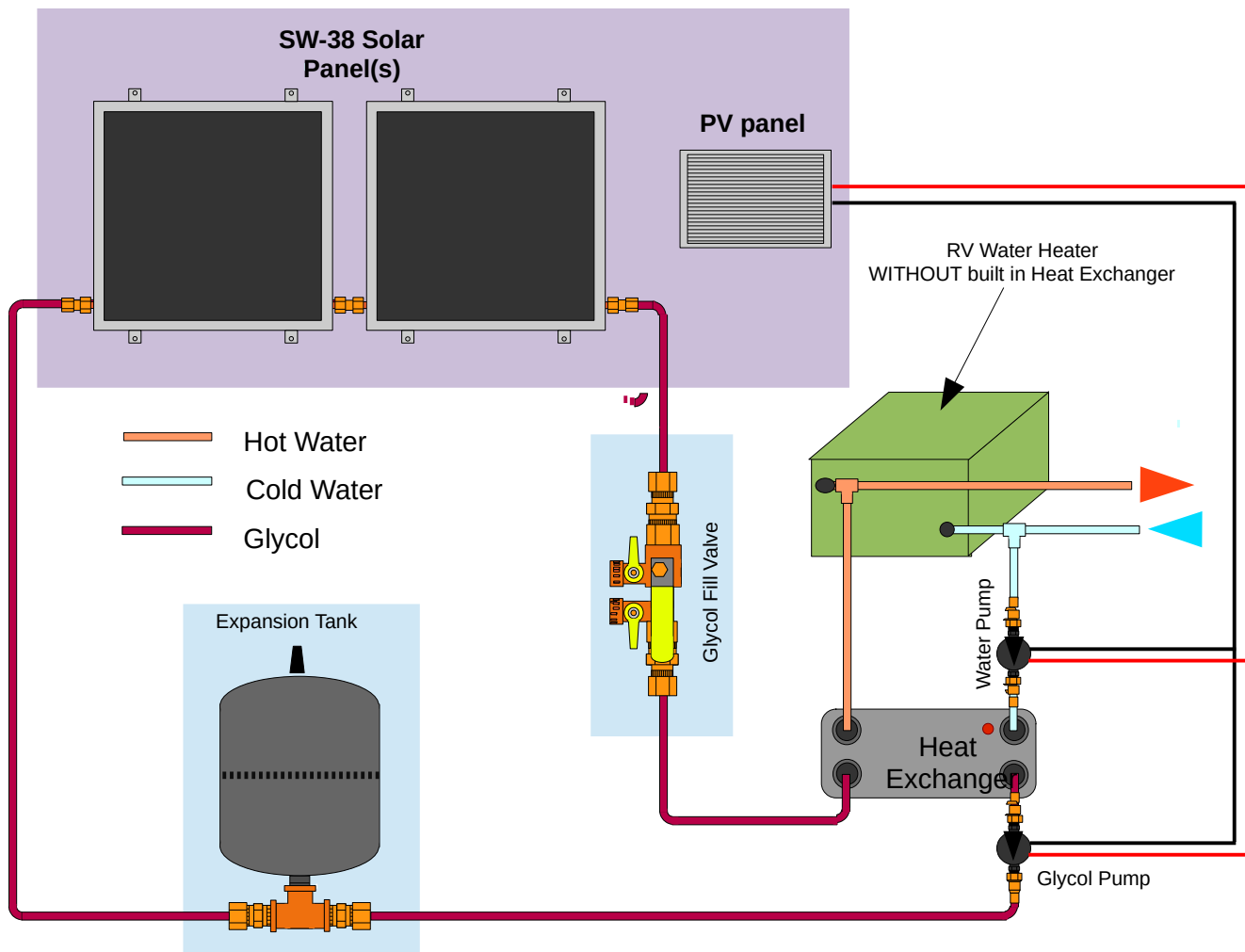

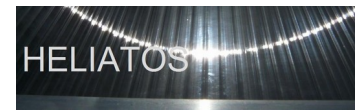

Introduction

This document describes how to install a Heliatos RH type solar water heating system. These systems use SW-38 Solar Water Heating Panels in combination with a Stainless Steel Heat Exchanger. The circulation loop contains a freeze resistant non-toxic fluid. As a result there is no danger of the panels freezing and being damaged. The level of freeze protection can be selected by the dilution of the antifreeze fluid. We recommend using Propylene Glycol based RV antifreeze.

The SW series panels are designed to be easily installed on any flat surface. They are equipped with 3/8" compression fittings so making reliable tight connections between panels and to included 3/8" PEX tubing is easy and fast. No soldering or special tools are required.

It is the installer's responsibility to assure that the panels themselves as well as the method and place of installation are in full compliance with all applicable regulations. Please consult the datasheet for the panels you are considering and assure that they are permissible and appropriate for your application.

Surface Preparation and PV Panel Location

In general, the surface you are planning to use for your installation should be fairly flat. Our panels are unique in that they can accommodate a base that is up to 1/4" uneven under each panel. Because of the special polycarbonate glazing they can flex a small amount without damage. The panels are equipped with four "feet". Each foot has a hole that is sized for a #8 deck screw. If you are mounting the panels to a surface that is suitable for using exterior deck screws, they are ready to install out of the box. However, if you require bigger bolts, you will have to enlarge the holes with a drill.

If you are using a rack to tilt your panels towards the sun, please make sure the feet all rest flat on the surfaces of the rack and all feet are securely fastened to the rack. Rack mounted panels can be subject to large wind forces.

The PV (electric) panel that powers the pumps should be installed such that it gets the same sun as the water heating panels. This assures that the pumping power and heating are balanced. The two pumps are connected to the PV panel with the included wire. They are not interchangeable so please follow the instructions closely when installing the pumps. The panels themselves are strong enough to remain outside the RV at highway speeds, however the installer has to assure that the mounting can support the very large forces present due to air flow.

RH/BH-System Installation Instructions

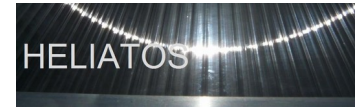

Step 1

Unpack the panels from the box and lay them on the installation surface next to each other. Each panel is connected to the next with a compression union. **One union is included with each panel in the green tube protectors.** The compression nuts that are pre-installed onto the tube in the panels thread onto the two ends of these unions.

The mounting tabs (feet) are not factory installed to prevent shipping damage. They are included in the gray tube protectors with the appropriate screws and need to be mounted to the panels before proceeding with the rest of the installation.

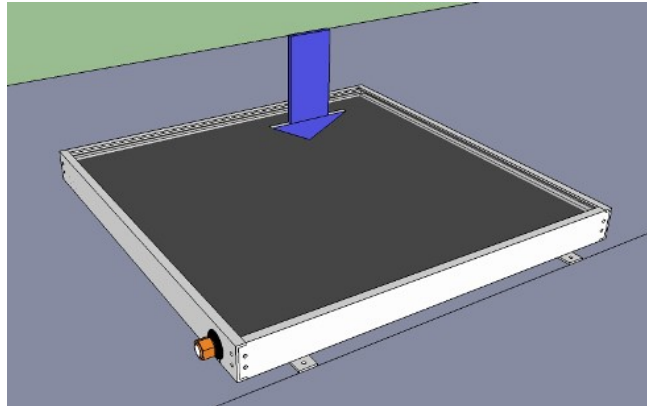

READ FIRST

Step 2

In this step (only applies if you have more than one panel) you connect the panels to each other. The connection is formed by the included compression unions. First some sealant has to be applied to the union. You should put a ring of sealant around the inside lip of both sides of the union as shown in the illustration.

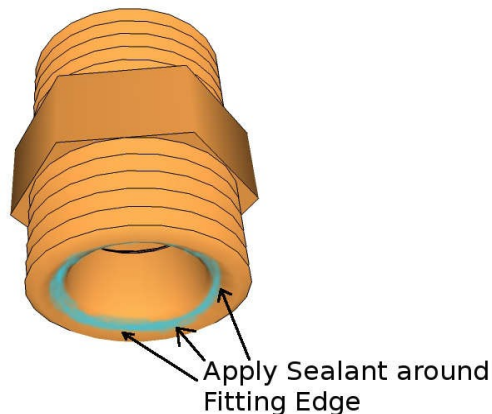

RH/BH-System Installation Instructions

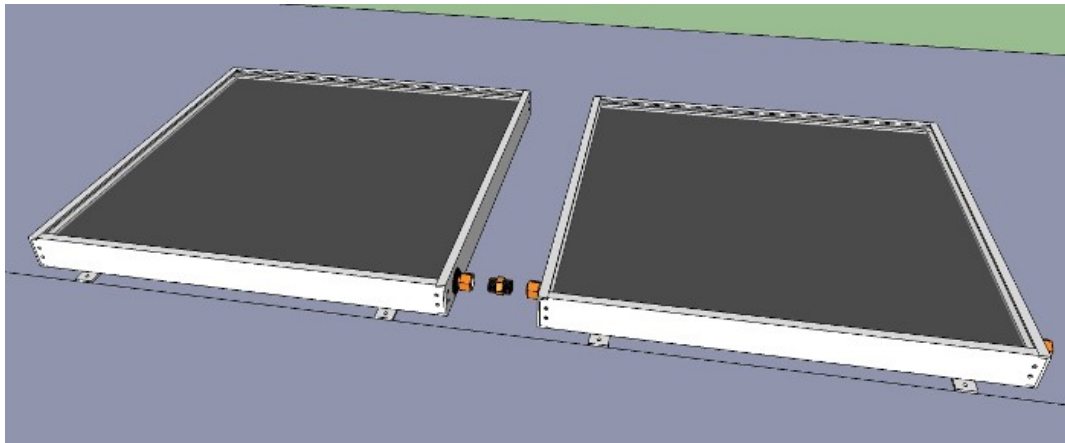
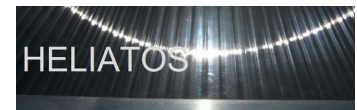

Start threading the union into the nuts on one panel and hand tighten only to allow some flexibility when lining up the panels. Bring the panels close to each other so the nuts on the second panel can be threaded onto the union, hand tighten. Slightly tighten the nuts on both sides. Not much torque is needed to form a tight seal. Once all the panels are connected further tighten each nut by about 1 turn.

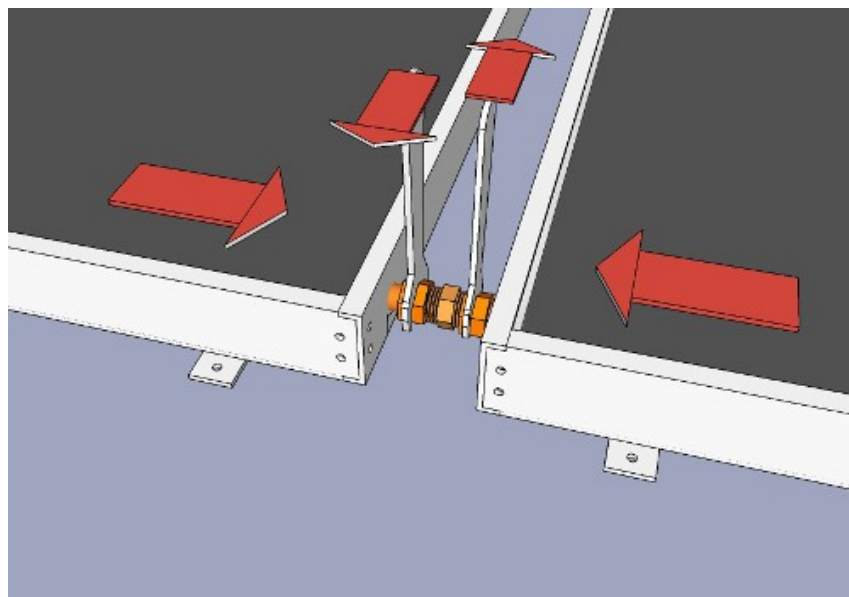

RH/BH-System Installation Instructions

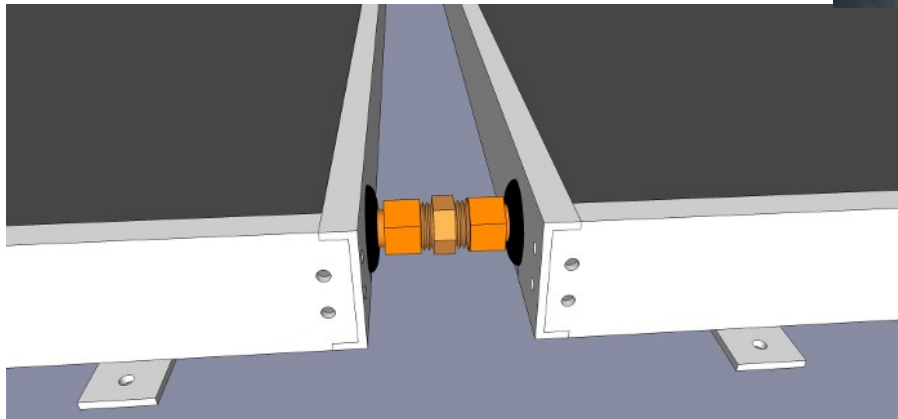
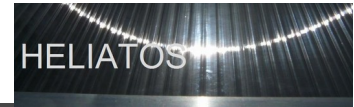

Repeat steps 1 and 2 for all your panels

Step 3

This installation manual assumes that you have one of our Connection Fittings kits. These kits contain all the fittings needed to make the connection, but since all the components use standard fittings it would also be possible to obtain all the parts at a local home improvement center or plumbing supply.

The direction of flow through the array of panels does not matter. It can go from left to right or the other way around.

First thread one 3/8" compression union into the nuts on the two end panels (left and right) and hand tighten. Apply sealant as in step 2.

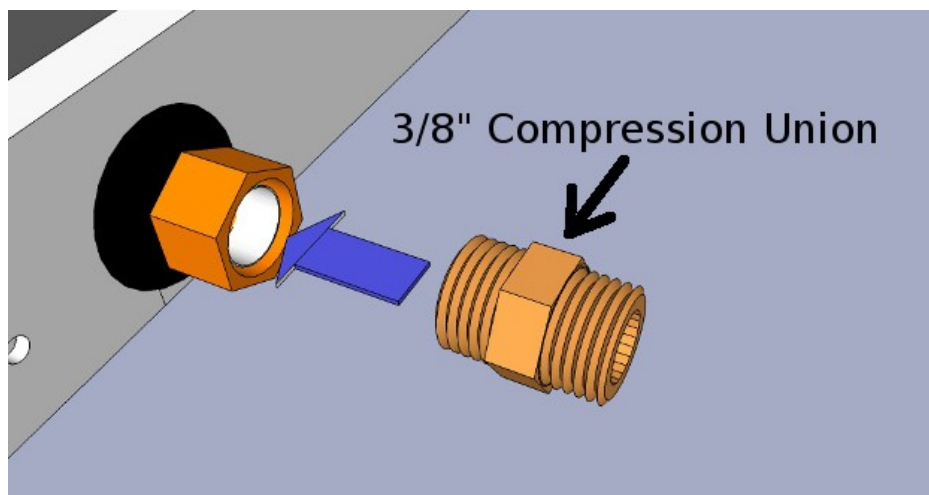

RH/BH-System Installation Instructions

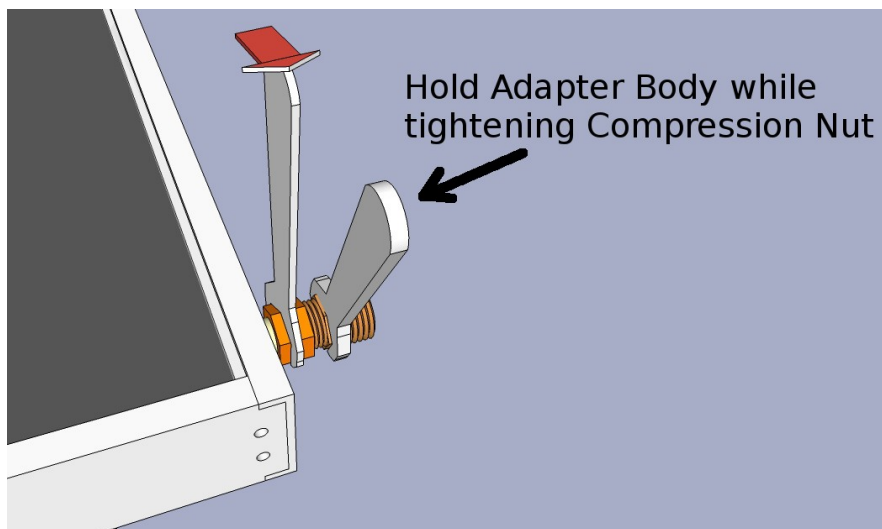
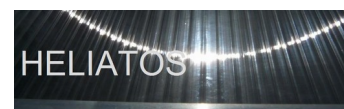

Next slide a compression nut onto both tubes followed by a nylon ferrule ferrule (ring). Insert a brass insert into the end of the PEX tubing to give it the extra strength needed for a good seal with compression fittings.

Finally push the tubes into the 3/8" compression unions and thread the compression nuts onto the union. Hand tighten and then tighten an additional turn.

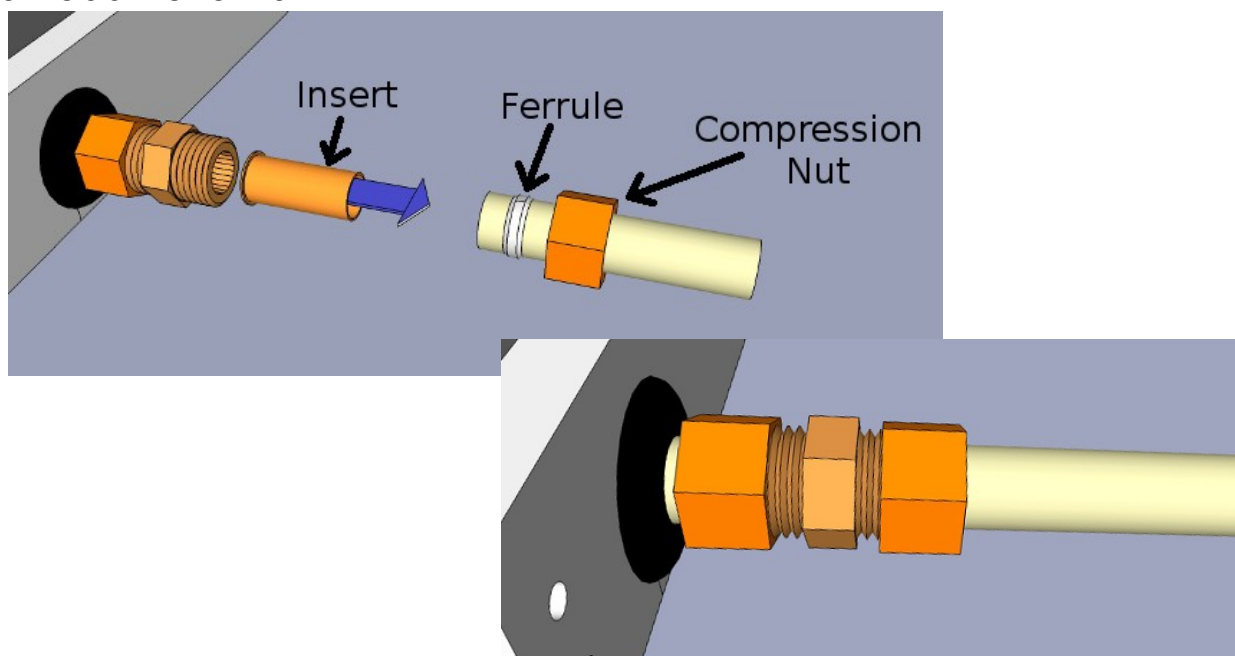

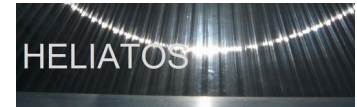

Step 4

The panel array has to be securely tied down. This is especially true if it is mounted on a rack or on rails so that wind can catch the panels from below. We show a simple set of deck screws here, but depending what method you are planning to use you should follow the directions provided with your mounting hardware.

Please remember that these panels are very light so that under no circumstances can you rely on their weight to hold them in place.

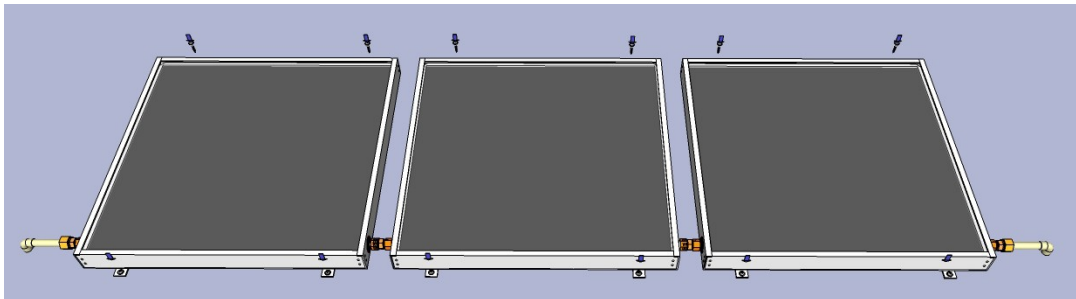
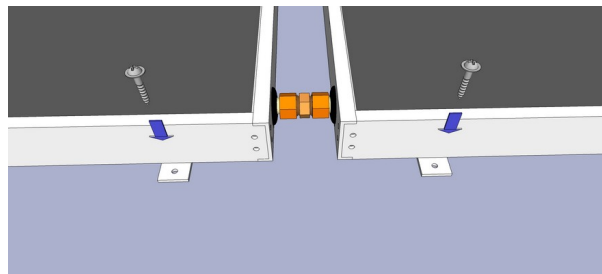

Mounting directly on a flat surface as well as on racks or rails is accomplished in a similar way. To achieve full wind loading capability it is important to attach all tabs securely to your mounting system.

Step 5

The exposed fittings and pipes have to be insulated next. This can be done by surrounding each joint with a foam or fiberglass sleeve. If you are using plastic foam a piece of aluminum adhesive tape should be wrapped around the foam sleeve to prevent rapid UV degradation. Install a foam sleeve over every fitting between panels as well as at the ends of the panel array.

RH/BH-System Installation Instructions

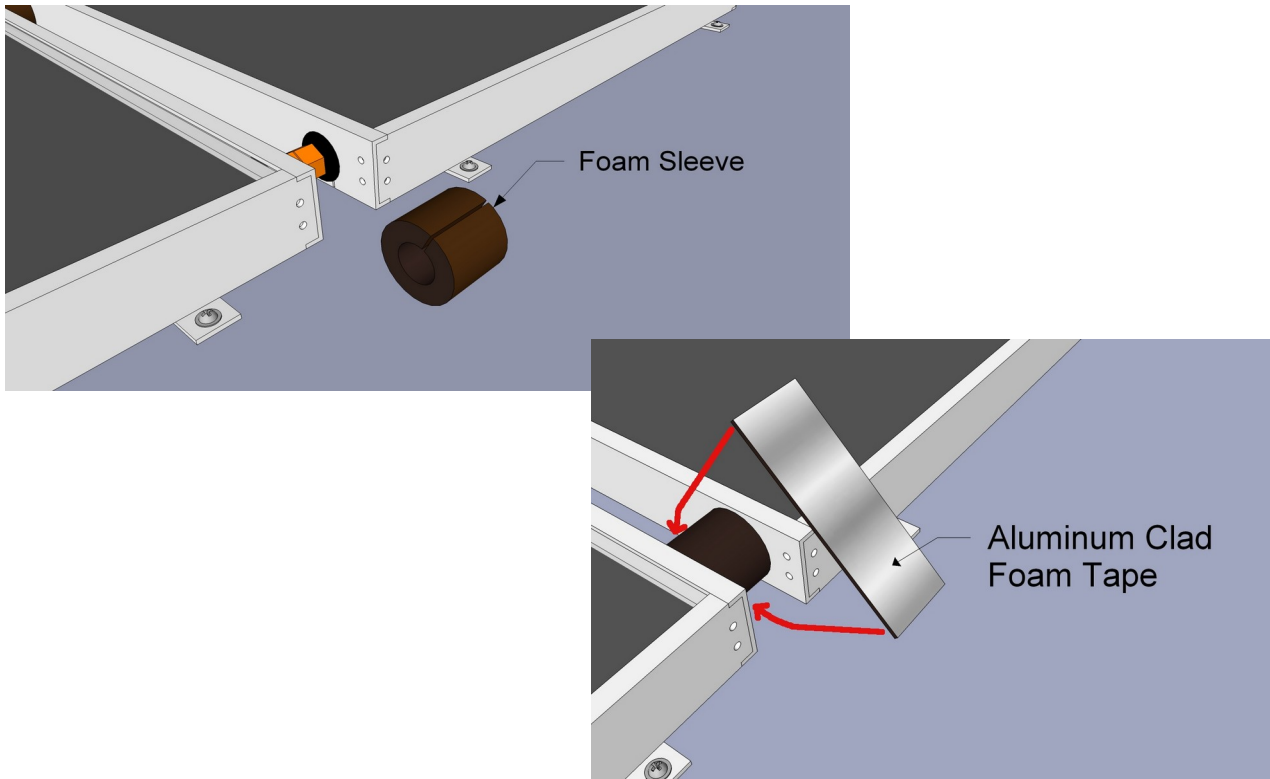
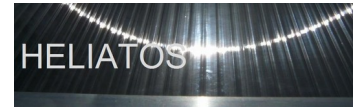

Completed Array Installation

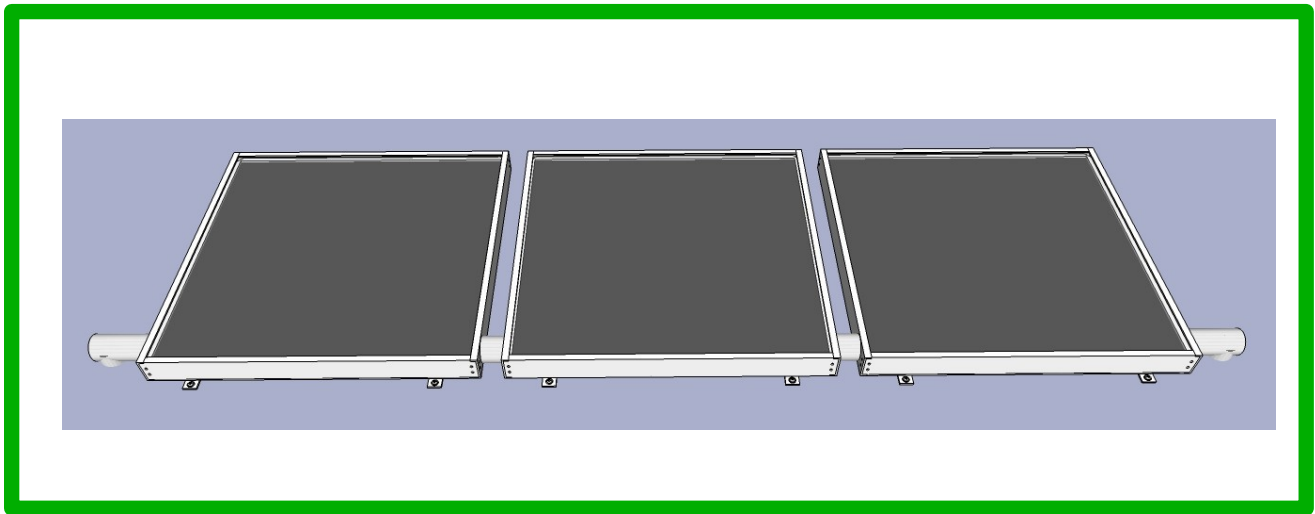

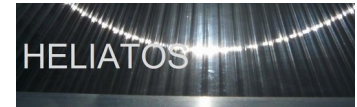

BEFORE YOU BEGIN

There are three sections left to complete the installation (Heat Exchanger, Glycol Fill Valve, Expansion Tank). While they are independent of each other you should familiarize yourself with all three before proceeding to make sure the plumbing installation fits all three components cleanly.

Heat Exchanger Assembly

It is important to install the respective parts on the right ports. If you cross ports the glycol and water loops will not be separate and your domestic water supply will be contaminated with glycol.

Thread the two brass elbows onto the heat exchanger using **plumbing sealant**. If you hold the heat exchanger facing you with the red dot on the bottom right side the elbows go on the two left side ports.

Thread hex couplings onto the ports on the right. Then thread street elbows into the couplings using **plumbing sealant** on both.

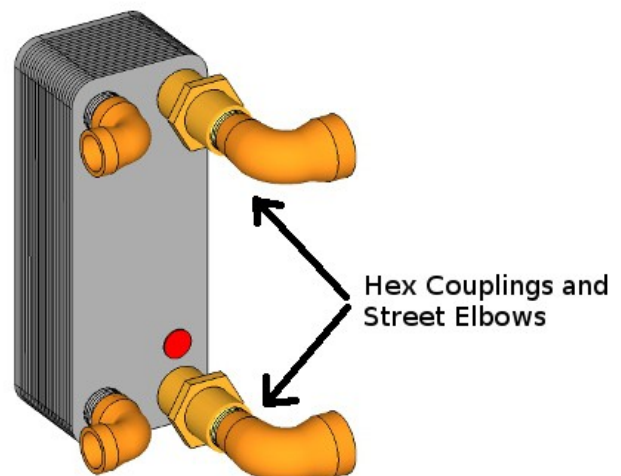
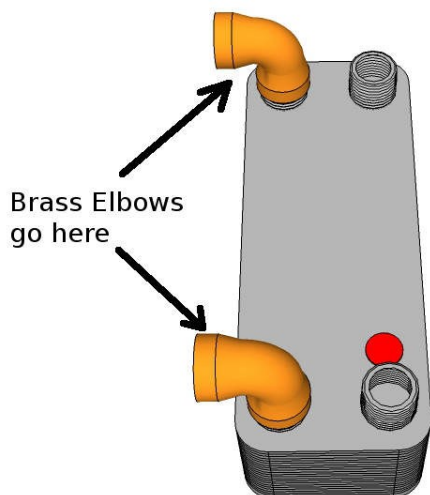

RH/BH-System Installation Instructions

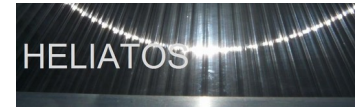

This kit includes 2 pumps. One is a TopsFlo TD5 pump which has a full stainless body. The second is a Heliatos HS-21 pump which has an all black Ryton body.

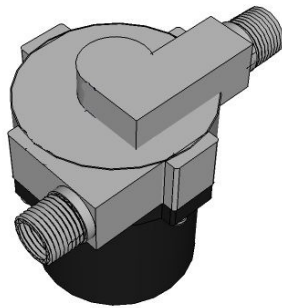

TD5

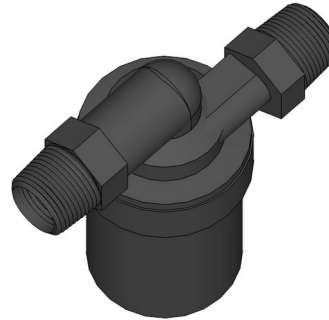

HS-21

Thread the TD5 into the street elbow near the red dot and the HS-21 into the elbow to the left using a generous amount of **Teflon Tape**. The HS-21 should pump **AWAY** from the heat exchanger and the TD5 pump **INTO** the heat exchanger. The arrow on the pump body points towards the output side and should be in the direction of the red arrow in the illustration. **On the HS-21 please use a wrench on the thread you are installing, NOT the one on the opposite side of the pump. The pump cannot withstand tightening torque.**

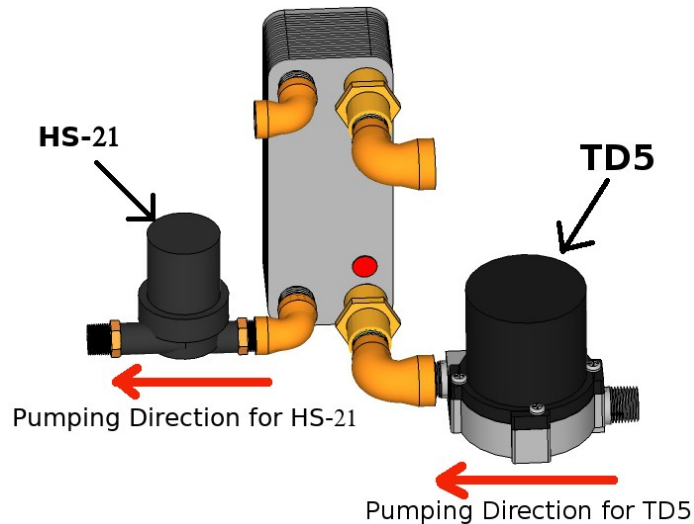

Thread the 3/8"OD Compression to 1/2" Female Pipe Adapter onto the remaining ports of both pumps and the 3/8"OD Compression to 1/2" Male Pipe Adapters into the street elbow and the normal elbow.

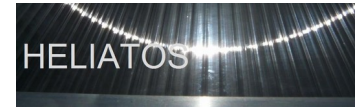

Glycol and Water Connections

Connecting the solar water heater to the existing plumbing entails using the two included 1/2" tees inserted in the cold supply to the water heater and the hot output from the water heater respectively. Most standard RV water heaters have 1/2" female threaded ports. The fittings kit supplied includes two 1/2" nipples which can be threaded into the water heater ports followed by the two tees. This leaves two openings on each of the tees. The diagram on page 1 shows how the connections are made to and from the various parts of the system. It is critical that the connections to the heat exchanger are made exactly as shown in the following image:

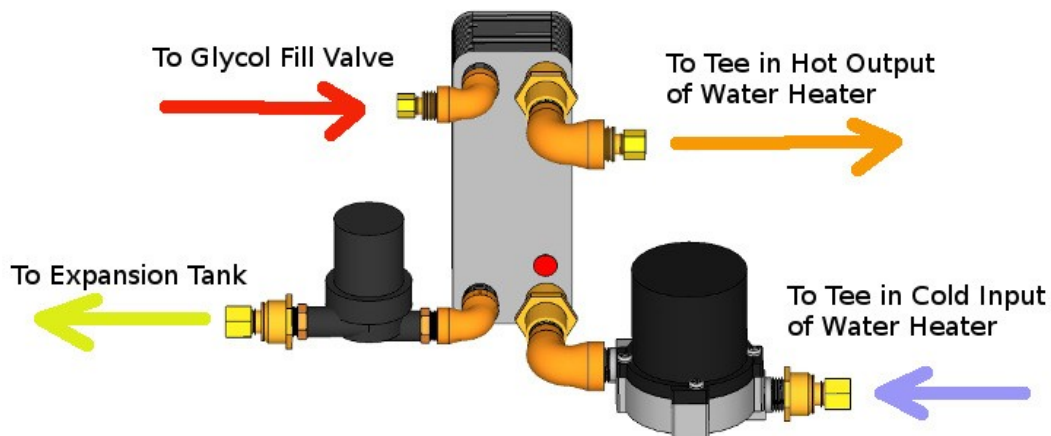

Electrical Connections

Both pumps have to be connected to the 20W PV panel on the roof with the included wire. Connect both red wires from the pumps to the red wire from the PV panel and both black wires from the pumps to the black wire from the PV panel and secure the connections with the included wire nuts.

The TD5 pump has a small hole in the back which allows you to select the power setting. A small plastic key is included with the pump to enable you to set the setting.

It is very important to set this pump so the arrow points between the two number 1's. If this setting is not set correctly the entire system will not function properly.

The HS-21 does not need to be set up.

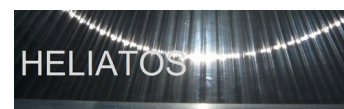

Installing the Glycol Fill Valve

The installation of the Glycol Fill Valve is described in the instructions that are included in the box with the item itself.

While it can be installed anywhere on the hot return line it is worthwhile to choose the location carefully. Using this valve involves pouring the glycol in a bucket or similar container and extending two two foot hoses (included with the item) into the glycol in the bucket. Therefore it makes sense to locate the fill valve in a place that makes this process easy. Usually this would be on the hot return line close to where it connects back to the heat exchanger so that the bucket can be set on the ground near the water heater.

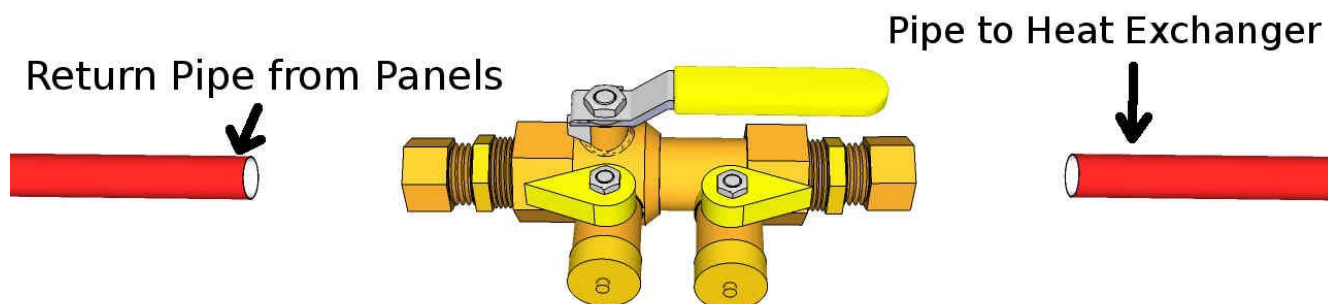

For proper operation and to eliminate the risk of toxic contamination of your RV plumbing we recommend Propylene Glycol RV Antifreeze fluid.

DO NOT use ethanol based RV Antifreeze or Ethylene Glycol (Automotive Antifreeze).

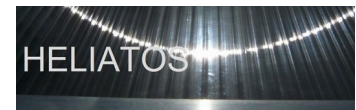

Installing the Expansion Tank

Install the expansion tank inline with the cool feed line going TO the panels. The fittings kit includes a 1/2" brass tee and two 3/8" compression two 1/2" male pipe adapters. First thread the two adapters into the tee and then thread this assembly onto the expansion tank using [sealant](#).

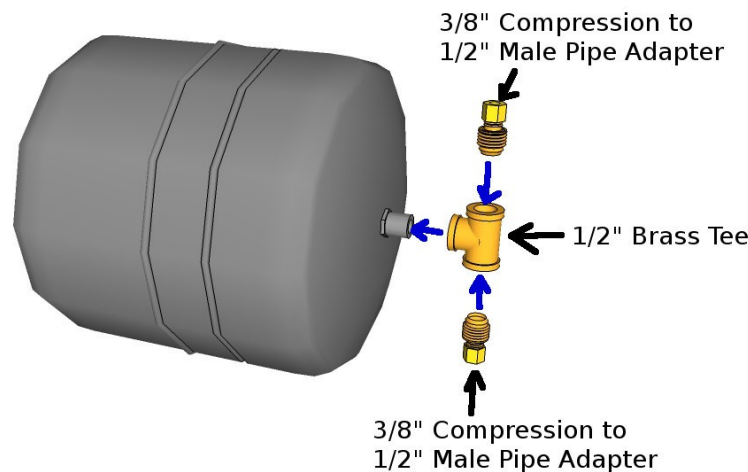

Once the expansion tank fitting has been installed you can install the tank inline on the pipe carrying the cooler glycol from the heat exchanger to the panels. The location along this line is not important.

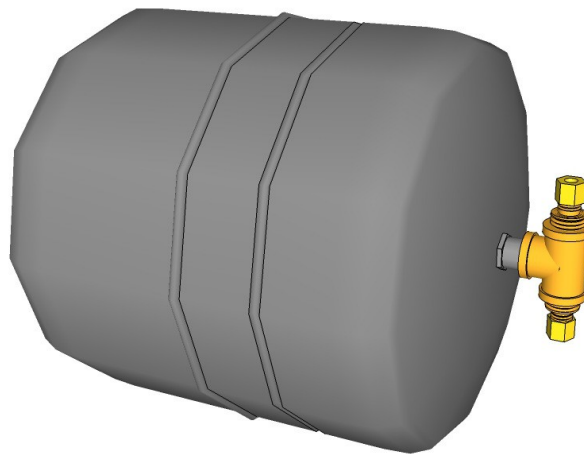

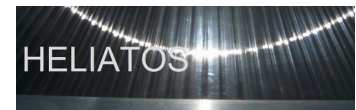

General Installation Hints

- No matter how warm the climate at your location the insulation of all exposed fittings / pipe is extremely important. Even small exposed areas will cause a lot of the solar heat to be lost. **The system WILL NOT FUNCTION PROPERLY until ALL the insulation is installed.**
- Please observe the polarity of the pumps connecting the positive supply to the red wire and the negative to the black wire. Reversing the polarity will immediately destroy the electronics in the pumps.
- It is important to set the power setting on the TD5 pump correctly
- If the fittings on the panels get very hot but the fittings on the heat exchanger do not it is highly likely that the glycol loop was not filled completely. Please try to flush the glycol loop one more time to remove any remaining air pockets.