

## General System Layout Sketch

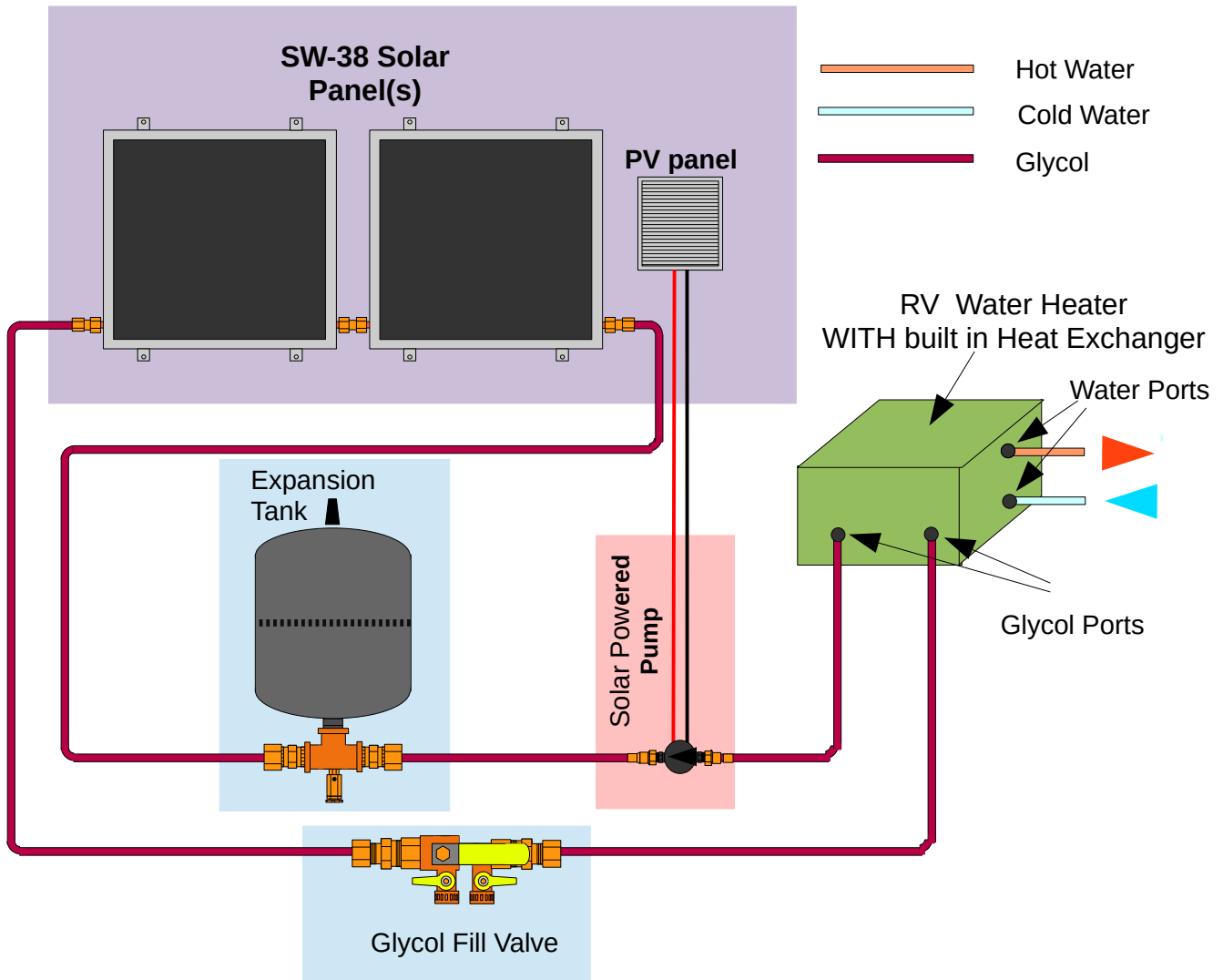

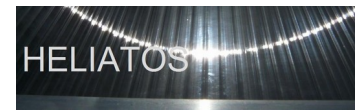

## Introduction

This document describes how to install a Heliatos RV/Boat Freeze Protected type solar water heating system. These systems use SW-38/MH-38 Solar Water Heating Panels to heat glycol or antifreeze circulating through the panels and the heat exchanger built into the water heater. These panels are designed to be easily extremely robust yet lightweight to stand up to mobile use. They are equipped with 3/8" compression fittings so making reliable tight connections between panels and to included 3/8" PEX tubing is easy and fast. No soldering or special tools are required.

**It is the installer's responsibility to assure that the panels themselves as well as the method and place of installation are in full compliance with all applicable regulations. Please consult the datasheet for the panels you are considering and assure that they are permissible and appropriate for your application.**

## Surface Preparation and PV Panel Location

In general, the surface you are planning to use for your installation should be fairly flat. Our panels are unique in that they can accommodate a base that is up to 1/4" uneven under each panel. Because of the special polycarbonate glazing they can flex a small amount without damage. The panels are equipped with four "feet". Each foot has a hole that is sized for a #8 deck screw. If you are mounting the panels to a surface that is suitable for using exterior deck screws, they are ready to install out of the box. However, if you require bigger bolts, you will have to enlarge the holes with a drill. Do not make the holes larger than 1/4", as the feet will not have sufficient strength to hold the panels down.

If you are using a rack to tilt your panels towards the sun, please make sure the feet all rest flat on the surfaces of the rack and all feet are securely fastened to the rack. Rack mounted panels can be subject to large wind forces.

The PV (electric) panel that powers the pumps should be installed such that it gets the same sun as the water heating panels. This assures that the pumping power and heating are balanced. The panels themselves are strong enough to remain outside the RV at highway speeds, however the installer has to assure that the mounting can support the very large forces present due to air flow.

# RG/BG - System Installation Instructions

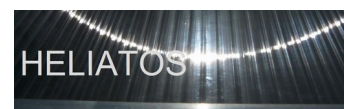

## Step 1

Unpack the panels from the box and lay them on the installation surface next to each other. Each panel is connected to the next with a compression union. **One union is included with each panel in the green tube protectors.** The compression nuts that are pre-installed onto the tube in the panels thread onto the two ends of these unions.

**The mounting tabs (feet) are not factory installed to prevent shipping damage. They are included in the gray tube protectors with the appropriate screws and need to be mounted to the panels before proceeding with the rest of the installation.**

**READ FIRST**

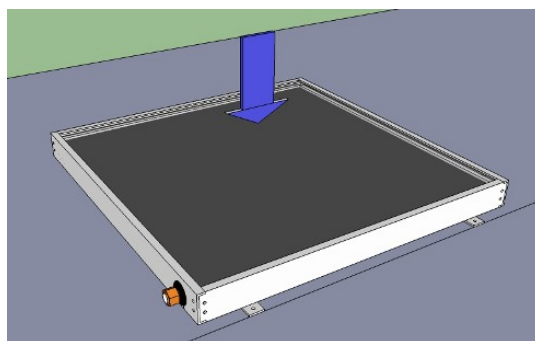

## Step 2

In this step (only applies if you have more than one panel) you connect the panels to each other. The connection is formed by the included compression unions. First some sealant has to be applied to the union. You should put a ring of sealant around the inside lip of both sides of the union as shown in the illustration.

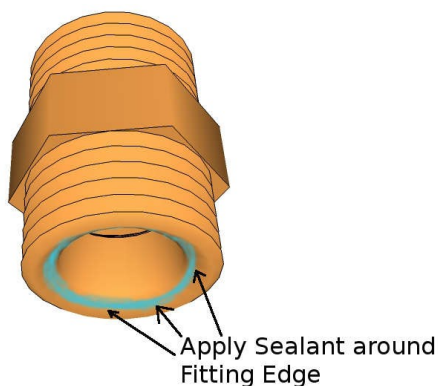

# RG/BG - System Installation Instructions

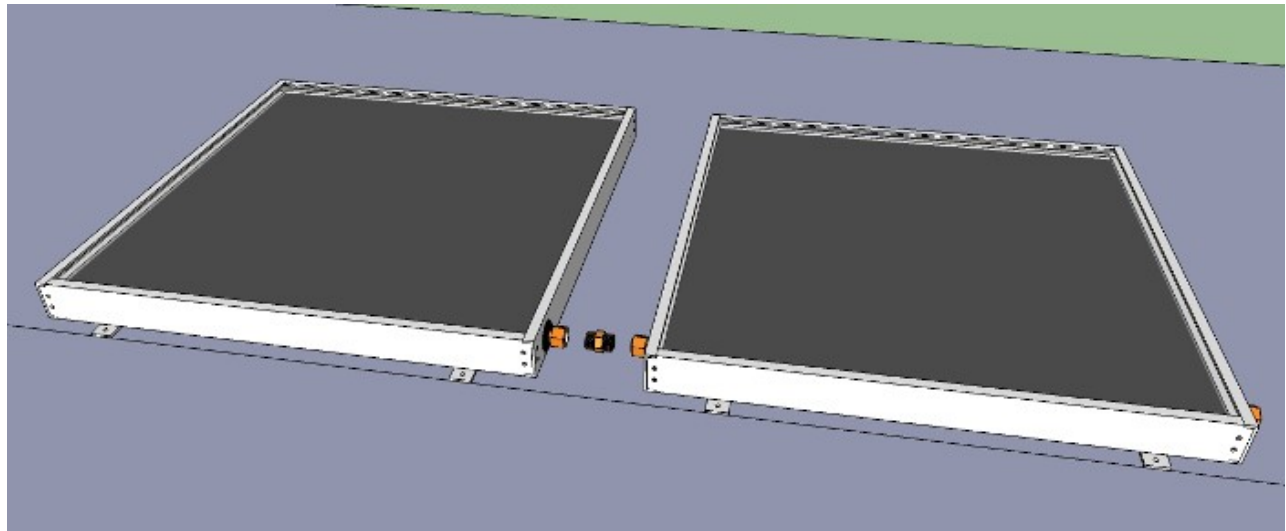
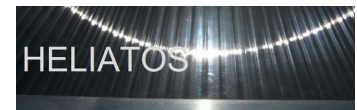

Start threading the union into the nuts on one panel and hand tighten only to allow some flexibility when lining up the panels. Bring the panels close to each other so the nuts on the second panel can be threaded onto the union, hand tighten. Slightly tighten the nuts on both sides. Not much torque is needed to form a tight seal. Once all the panels are connected further tighten each nut by about 1 turn.

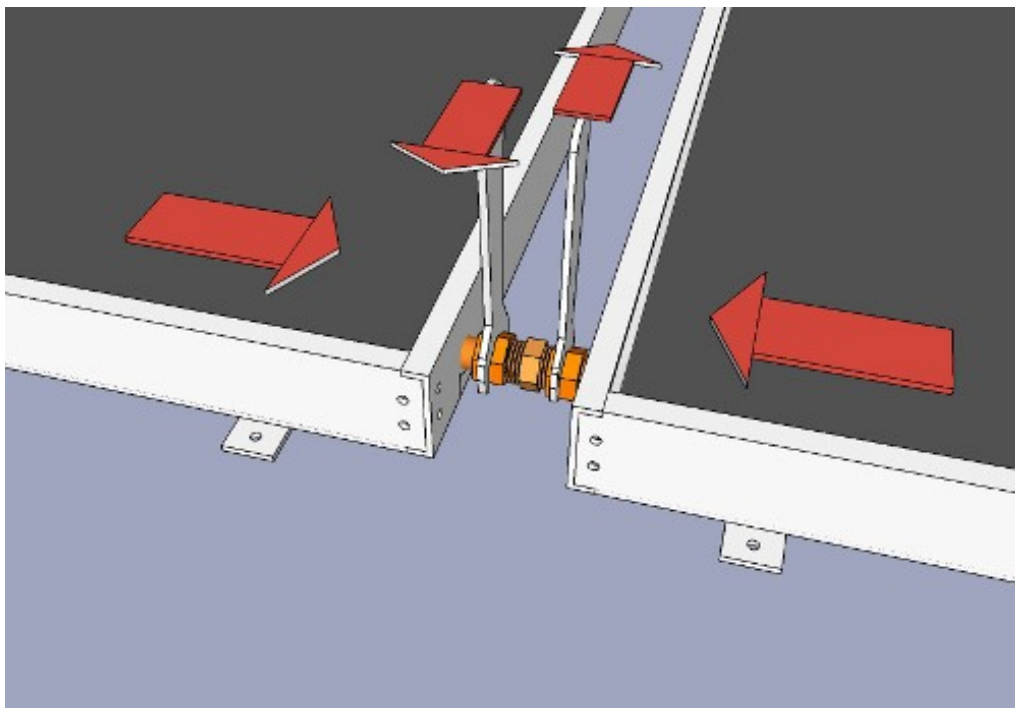

# RG/BG - System Installation Instructions

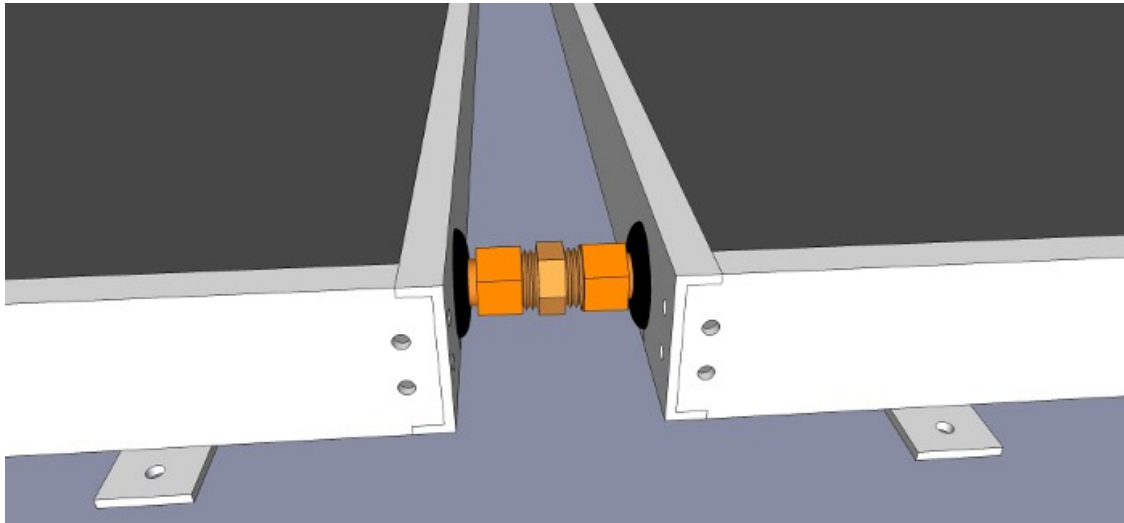
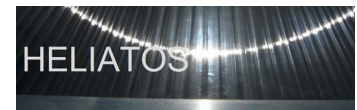

**Repeat steps 1 and 2 for all your panels**

## **Step 3**

This installation manual assumes that you have one of our Connection Fittings kits. These kits contain all the fittings needed to make the connection, but since all the components use standard fittings it would also be possible to obtain all the parts at a local home improvement center or plumbing supply.

The direction of flow through the array of panels does not matter. It can go from left to right or the other way around.

First thread one 3/8" compression union into the nuts on the two end panels (left and right) and hand tighten. Apply sealant as in step 2.

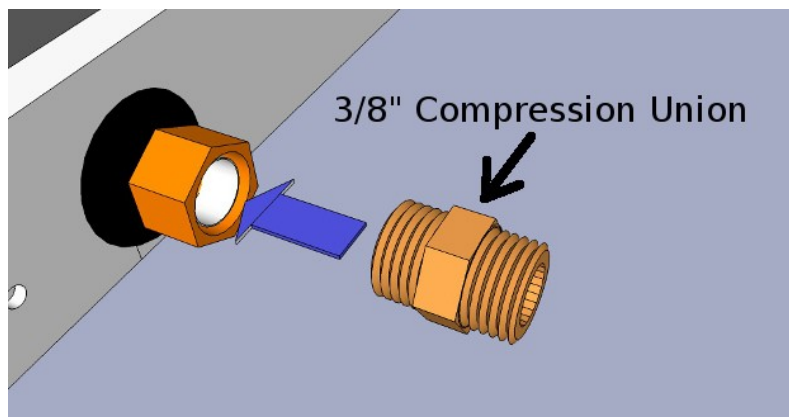

# RG/BG - System Installation Instructions

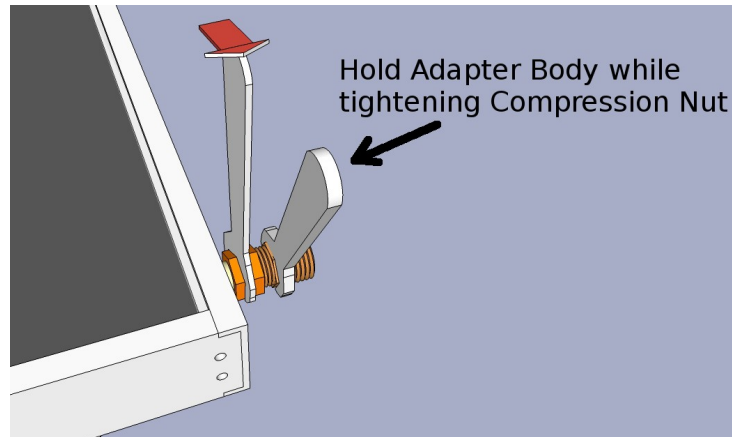
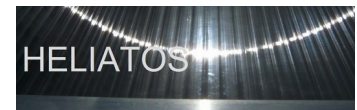

Next slide a compression nut onto both tubes followed by a nylon ferrule ferrule (ring). Insert a brass insert into the end of the PEX tubing to give it the extra strength needed for a good seal with compression fittings.

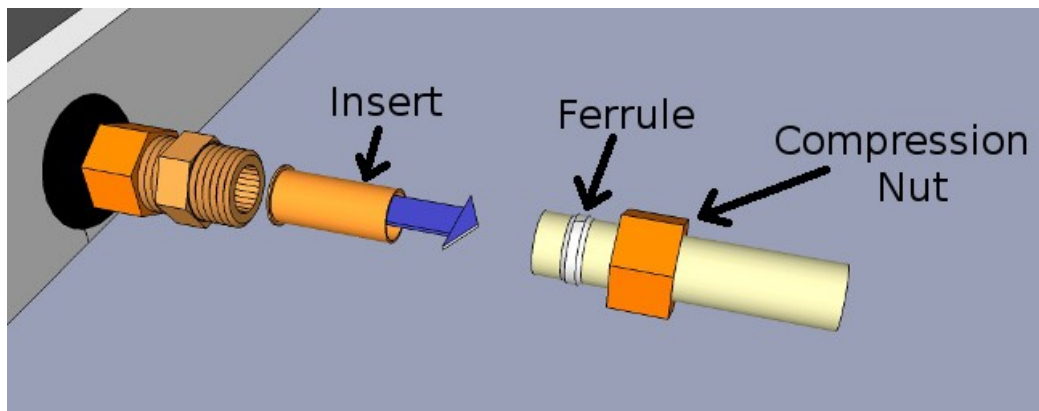

Finally push the tubes into the 3/8" compression unions and thread the compression nuts onto the union. Hand tighten and then tighten an additional turn.

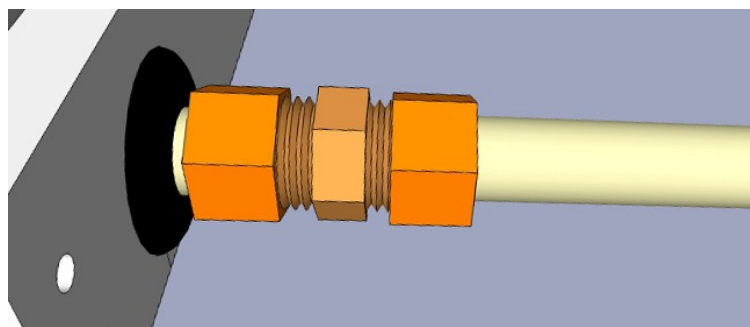

# RG/BG - System Installation Instructions

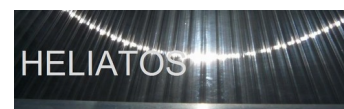

## Step 4

The panel array has to be securely tied down. This is especially true if it is mounted on a rack or on rails so that wind can catch the panels from below. We show a simple set of deck screws here, but depending what method you are planning to use you should follow the directions provided with your mounting hardware.

Please remember that these panels are very light so that under no circumstances can you rely on their weight to hold them in place.

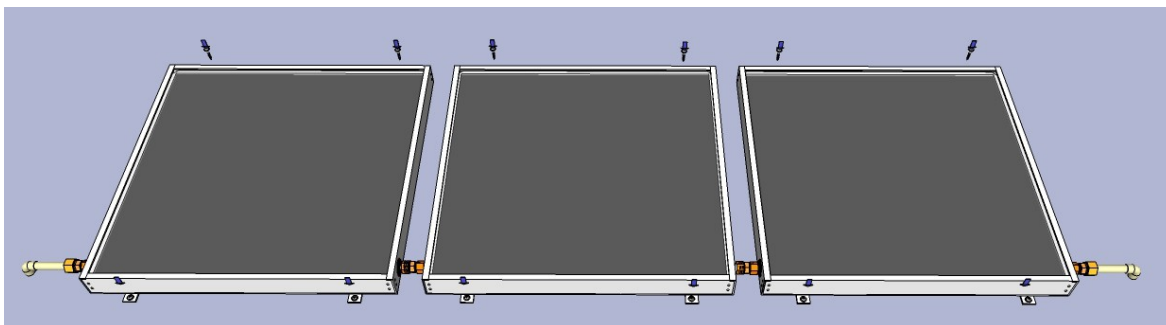
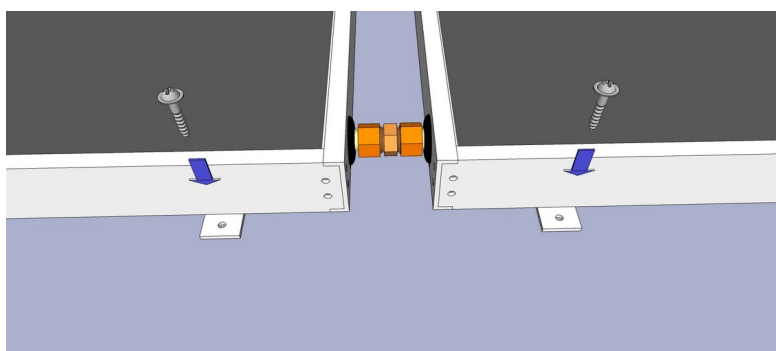

Mounting directly on a flat surface as well as on racks or rails is accomplished in a similar way. To achieve full wind loading capability it is important to attach all tabs securely to your mounting system.

## Step 5

The exposed fittings and pipes have to be insulated next. This can be done by surrounding each joint with a foam or fiberglass sleeve. If you are using plastic foam a piece of aluminum adhesive tape should be wrapped around the foam sleeve to prevent rapid UV degradation.

# RG/BG - System Installation Instructions

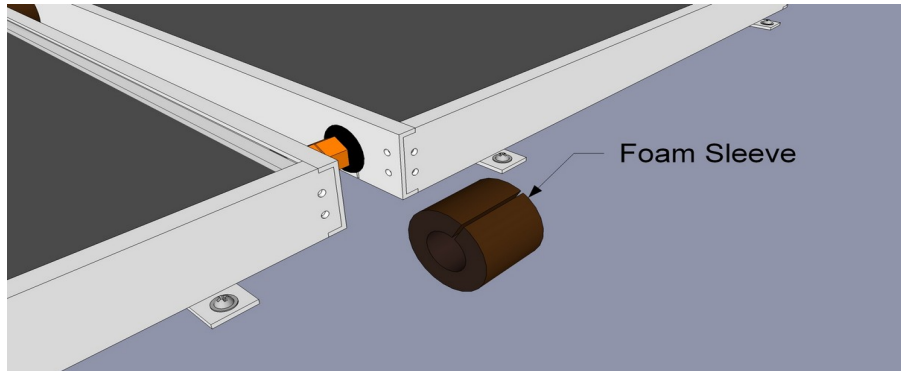
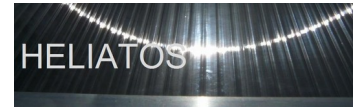

Install a foam sleeve over every fitting between panels as well as at the ends of the panel array.

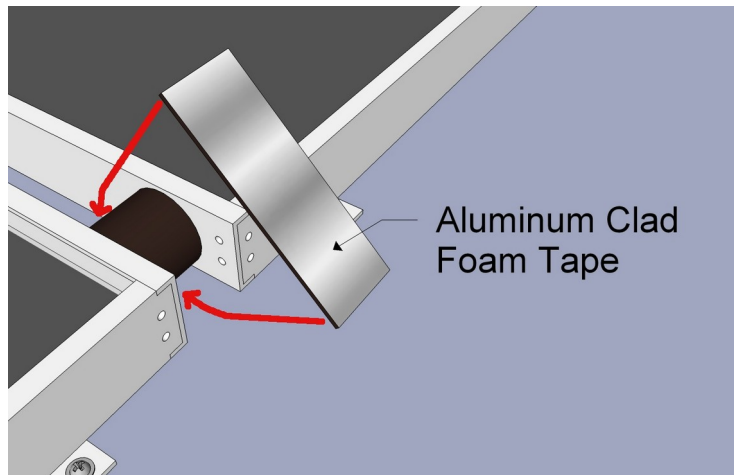

## Completed Array Installation

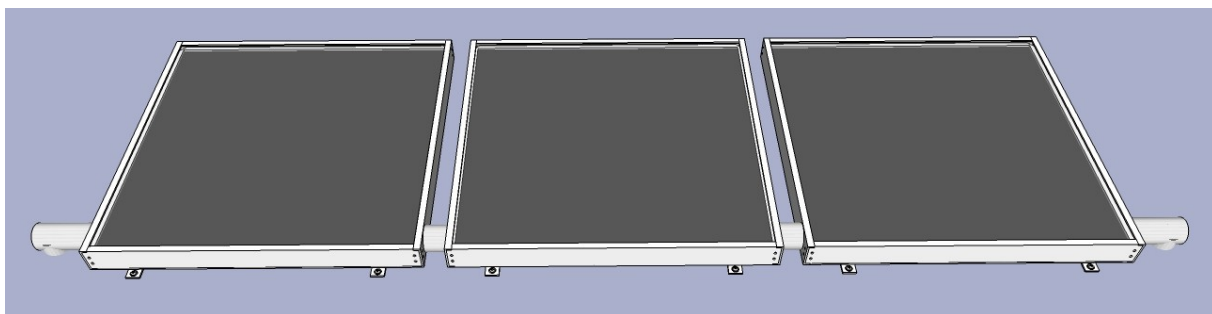

# RG/BG - System Installation Instructions

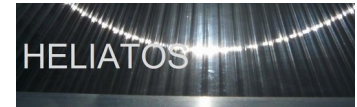

## BEFORE YOU BEGIN

There are four sections left to complete the installation (Heat Exchanger Connections on the tank, Circulation Pump, Expansion Tank, and Glycol Fill Valve). While they are independent of each other you should familiarize yourself with all four before proceeding to make sure the plumbing installation fits all components cleanly.

The following steps apply to most standard water heaters found in RV's and boats, however these water heaters are not standardized to the extent that residential ones are. If you find that your unit is substantially different or the following installations instructions do not apply to your existing water heater please contact us with as many details about your installation as possible (photographs are most helpful). We will work with you in finding the easiest way to connect your system.

### Step 1

Locate the two heat exchanger ports on your water heater. If the other (water) ports are already connected there is no need to disconnect them.

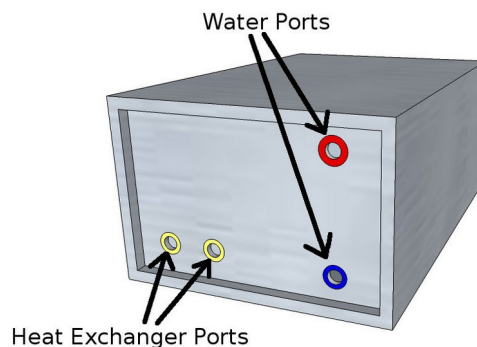

Install 2 of the 4 included 3/8" Compression to 1/2" Male NPT adapters into the heat exchanger ports.

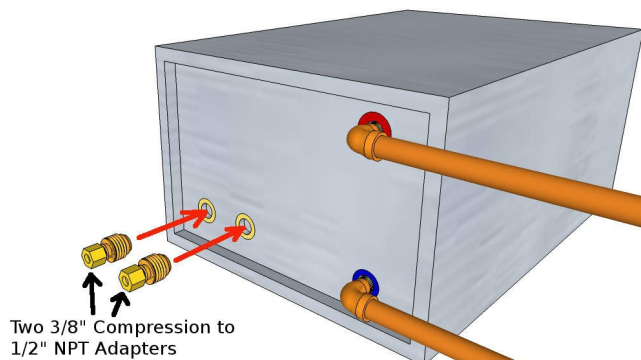

# RG/BG - System Installation Instructions

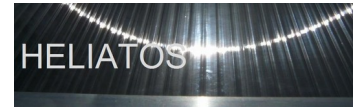

## Step 2

To prepare the pump thread the two 3/8" compression to 1/2" female pipe adapters onto the two sides of the pump. **Please use two wrenches on the thread and adapter you are installing, NOT the one on the opposite side of the pump. The pump cannot withstand tightening torque.**

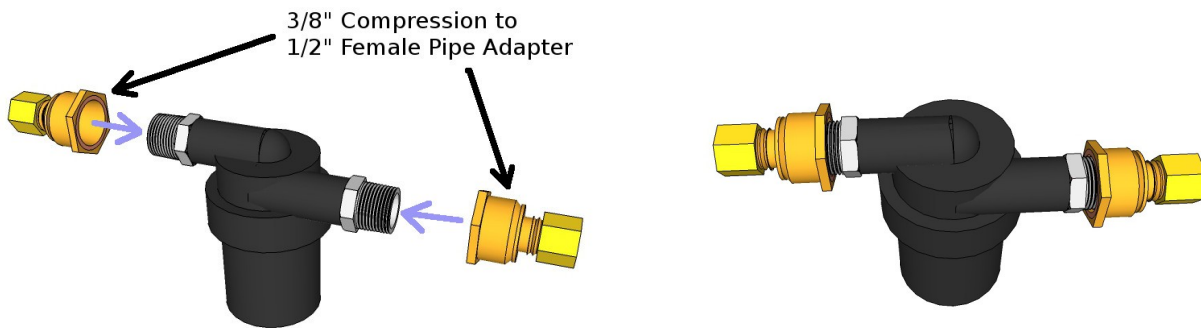

## Step 3

Install the expansion tank inline with the cool feed line going TO the panels. The fittings kit includes a 1/2" brass tee and two 3/8" compression to 1/2" male pipe adapters. First thread the two adapters into the tee and then thread the assembly onto the expansion tank using **sealant**.

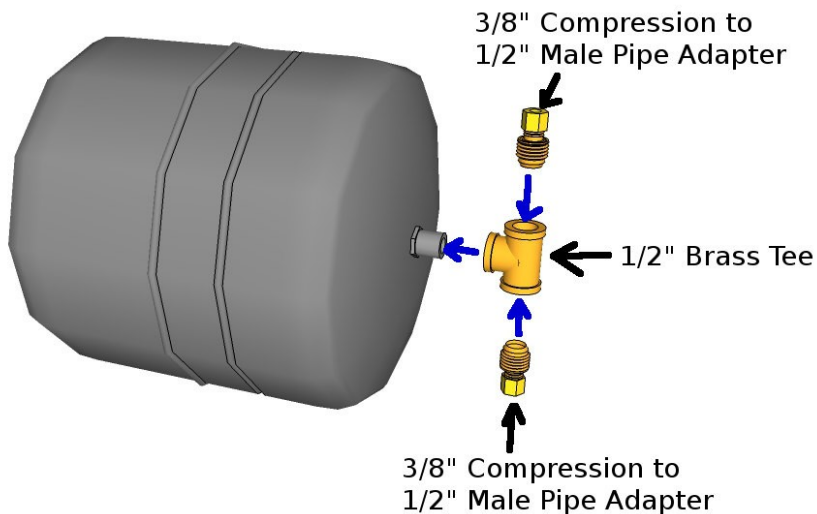

# RG/BG - System Installation Instructions

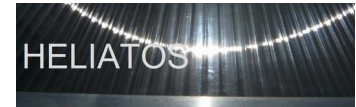

Once the expansion tank fitting has been installed you can install the tank inline on the pipe carrying the cooler glycol from the heat exchanger to the panels. The location along this line is not important.

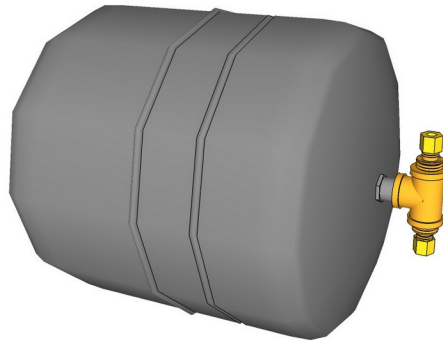

## Step 4

The installation of the Glycol Fill valve is described in the instructions that are included in the box with the item itself.

While it can be installed anywhere on the hot return line it is worthwhile to choose the location carefully. Using this valve involves pouring the glycol in a bucket or similar container and extending two two foot hoses (included with the item) into the glycol in the bucket. Therefore it makes sense to locate the fill valve in a place that makes this process easy. Usually this would be on the hot return line close to where it connects back to the heat exchanger so that the bucket can be set on the ground near the water heater.

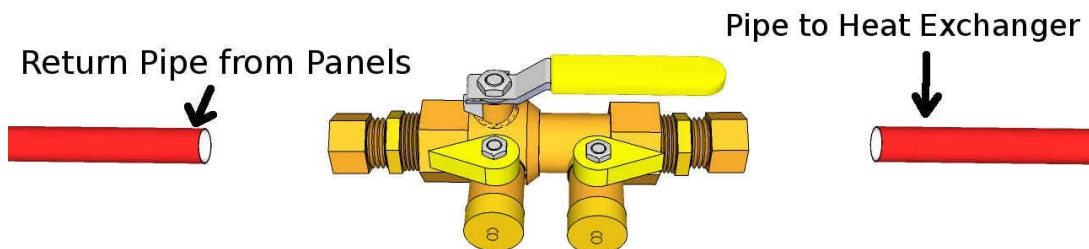

**DO NOT use ethanol based RV Antifreeze or Ethylene Glycol (Automotive Antifreeze).**

For proper operation and to eliminate the risk of toxic contamination of your RV plumbing we recommend Propylene Glycol RV Antifreeze fluid.

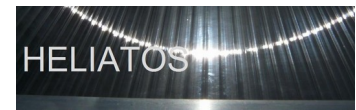

## Step 5

Now all the fittings are ready to be connected. The system diagram on the front page of this document shows the general layout of the connections. Near the water heater the pump has to be connected to the tee on one of the heat exchanger ports pumping away from the water heater. The expansion tank should be installed between the pump and the panel(s). The glycol fill valve goes on the return line from the panels to the water heater.

The small PV panel has to be mounted next to the water heating panel(s) and is used to power the pump. This way the pump will provide flow that is proportional to the amount of sunshine which also supplies the heat into the water heating panels. Simply connect the positive (red) terminal on the PV panel to the red wire on the pump and the negative (black) terminal to the black wire of the pump.

### General Installation Hints

- No matter how warm the climate at your location the insulation of all exposed fittings / pipe is extremely important. Even small exposed areas will cause a lot of the solar heat to be lost. **The system WILL NOT FUNCTION PROPERLY until ALL the insulation is installed.**
- Please observe the polarity of the pump connecting the positive supply to the red wire and the negative to the black wire. Reversing the polarity will immediately destroy the electronics in the pump.
- If the fittings on the panels get very hot but the fittings on the heat exchanger do not it is highly likely that the glycol loop was not filled completely. Please try to flush the glycol loop one more time to remove any remaining air pockets.
- With any persistent problems please call (661)-7SOLAR7 (9am to 5pm pacific time) or email [support@heliatos.com](mailto:support@heliatos.com) for tech-support.